

1080Z 1040A Assembly

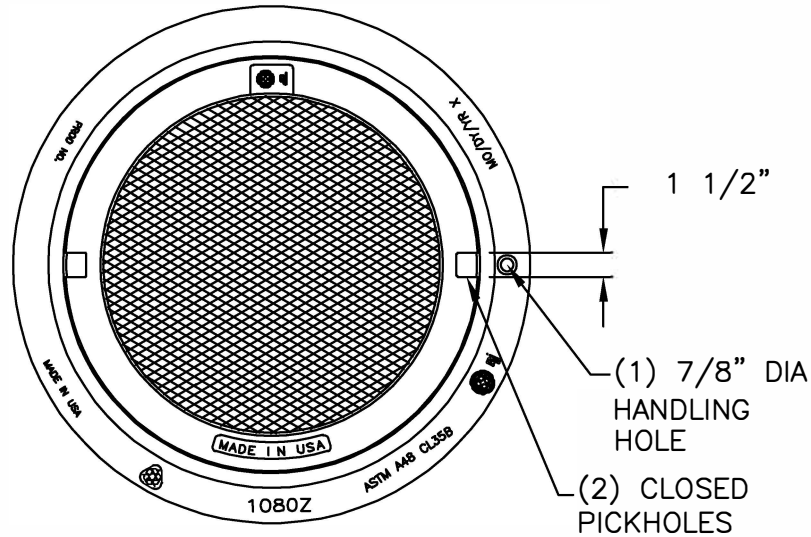

PLAN VIEW

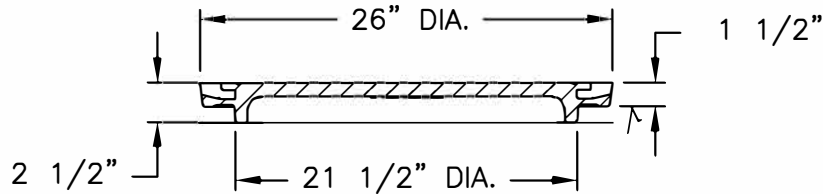

COVER SECTION

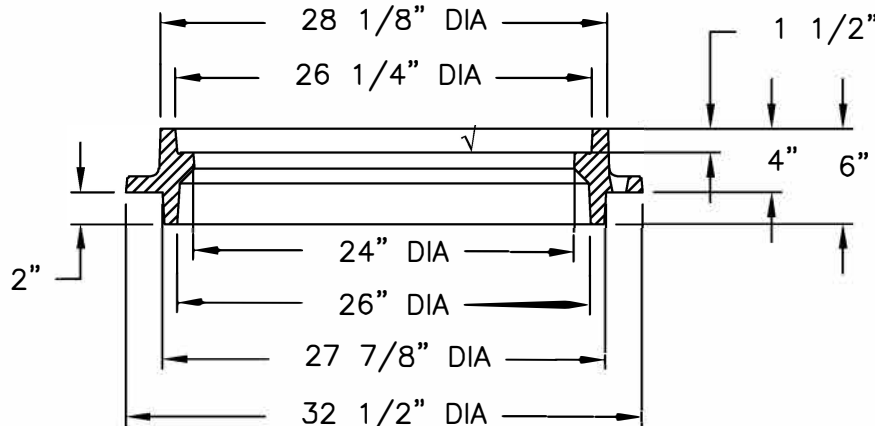

FRAME SECTION

Product Number

00104020A02

Design Features

- Materials
- Cover
- Gray Iron (CL35B)
- Frame
- Gray Iron (CL35B)

-Load Rating

Heavy Duty

-Open Area

n/a

-Coating

Dipped

-√ Designates Machined Surface

Certification

- ASTM A48
- ASTM A48

-Country of Origin: USA

Major Components

00104020

00108010

Drawing Revision

12/20/2023 Designer: MAH

Revised By:

Disclaimer

Weights (lbs./kg) dimensions (inches/mm) and drawings provided for your guidance. We reserve the right to modify specifications without prior notice.

CONFIDENTIAL: This drawing is the property of EJ GROUP, Inc., and embodies confidential information, registered marks, patents, trade secret information, and/or know how that is the property of EJ GROUP, Inc. Copyright © 2012 EJ GROUP, Inc. All rights reserved.

Contact

877.903.7246

trenchdrainsupply.com

Supplied By:

